

Distributed by:



[www.Jameco.com](http://www.Jameco.com) ♦ 1-800-831-4242

The content and copyrights of the attached material are the property of its owner.

Jameco Part Number 658953



# PRODUCT SPECIFICATION

## HDM64GS12L-4

128 x 64 GRAPHICS  
LCD DISPLAY MODULE

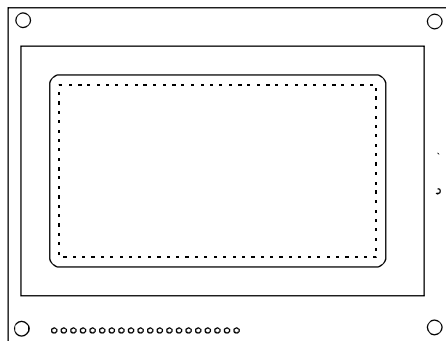

<b>HANTRONIX, INC.</b> 10080 BUBB RD. CUPERTINO, CA 95014	<b>Q.A.:</b>	<b>REV.:</b>	<b>HDM64GS12L-4</b>	<b>SHEET 1 OF 16</b>
	JK	1.2		<b>DATE:</b> 10/9/03

# 1. MECHANICAL DATA

(1) Product No.	HDM64GS12L-4
(2) Module Size	75.0(W)mm X 52.7(H)mm X MAX9.5(D)mm (LED B/L)
(3) Dot Size	0.40 (W)mm x 0.40 (H)mm
(4) Dot Pitch	0.43 (W)mm x 0.43 (H)mm
(5) Number of Dots	128 (W) x 64 (H)Dots
(6) Duty	1/64
(7) LCD Display Mode	STN: Yellow Mode
	Rear Polarizer: Transflective
(8) Viewing Direction	6 O'clock
(9) Backlight	LED B/L
(10) Weight	LED B/L : 35.6g(approx.)
(11) DC/DC Converter	Built-in

<b>HANTRONIX, INC.</b> 10080 BUBB RD. CUPERTINO, CA 95014	Q.A.:	REV.:	<b>HDM64GS12L-4</b>	SHEET 2 OF 16
	JK	1.2		DATE:

## 2. ABSOLUTE MAXIMUM RATINGS

### (1) ELECTRICAL ABSOLUTE RATINGS

VSS=0V

	SYMBOL	MIN	MAX	UNIT	COMMENT
Power Supply for Logic	VDD-VSS	-0.3	7.0	V	
Power Supply for LCM	VDD-VSS	0	21.0	V	
Input Voltage	VDD	-0.3	VDD	V	
Static Electricity	-	-	-	-	Note 1

### (2) ENVIRONMENTAL ABSOLUTE MAXIMUM RATINGS

ITEM	OPERATING		STORAGE	
	MIN.	MAX.	MIN.	MAX.
Ambient Temperature	-20	70	-30	80
Humidity (Without Condensation)	Note 2,3		Note 2,4	

Note 1 LCM should be grounded during handling LCM.

Note 2 Background color changes slightly depending on ambient temperature.  
This phenomenon is reversible.

Note 3 To  $\leq$  70°C : 75%RH max  
To > 70°C : Absolute humidity must be lower  
than the humidity of 75%RH at 70°C

Note 4 To at -30°C will be < 48hrs, at 80°C will be < 120hrs

<b>HANTRONIX, INC.</b> 10080 BUBB RD. CUPERTINO, CA 95014	Q.A.:	REV.:	<b>HDM64GS12L-4</b>	SHEET 3 OF 16
	JK	1.2		DATE:

### 3. ELECTRICAL CHARACTERISTICS

( VDD= 5.0±10%V )

ITEM	SYMBOL	CONDITION	MIN.	TYP.	MAX.	UNIT	
Input Voltage	V <sub>IH</sub>	H level	0.7VDD	-	VDD	V	
	V <sub>IO</sub>	L level	0	-	0.3VDD	V	
Recommended LC Driving Voltage (Low Voltage LC and Wide Temp. LCM)	VDD-V <sub>O</sub>	Duty= 1/64  Bias= 1/9	-20°C	9.8	10.1	10.4	V
			0°C	8.7	9.0	9.3	
			25°C	8.4	8.7	9.0	
			50°C	7.9	8.2	8.5	
			70°C	7.5	7.8	8.1	
Power Supply Current	I <sub>DD</sub>	FLM=79 Hz VDD=5.0 V VDD-V <sub>O</sub> =8.7 V PATTERN : □ ■ □ ■ □ ■ ■ □ ■ □ ■ □	-	2.0	5.0	mA	
LED B/L Supply Current	I <sub>LED</sub>	V <sub>LED</sub> =5.0 V R7=R8=10Ω (R7=10Ω)	-	150 (89)	200	mA	

# 4. OPTICAL CHARACTERISTICS

(For Wide Temperature Mode LCM)

AT Vop

ITEM		Cr(Contrast Ratio)										θ(Viewing Angle)		θ(Viewing Angle)	
		-20°C		0°C		25°C		50°C		70°C		25°C		25°C	
		MIN.	TYP.	MIN.	TYP.	MIN.	TYP.	MIN.	TYP.	MIN.	TYP.	MIN.	TYP.	MIN.	TYP.
S	C	2.0	4.5	3.5	5.5	5.0	6.0	3.5	5.5	2.0	5.0	-	67	-	26-45
NOTE		NOTE 6										NOTE 5			

NOTE :

S : TRANSFLECTIVE  
C : YELLOW

AT  $\theta=0^\circ$   $\theta=0^\circ$

ITEM	SYMBOL	CONDITION	MIN.	TYP.	MAX.	UNIT	NOTE
Response Time (rise)	Tr	-20°C	5500	11000	16500	ms	NOTE 2
		0°C	800	1600	2400		
		25°C	200	400	600		
		50°C	80	160	240		
		70°C	55	110	165		
Response Time (fall)	Tf	-20°C	3500	7000	10500	ms	NOTE 2
		0°C	400	800	1200		
		25°C	75	150	225		
		50°C	40	80	120		
		70°C	35	70	105		

HANTRONIX, INC.  
10080 BUBB RD.  
CUPERTINO, CA 95014

Q.A.:  
JK

REV.:  
1.2

HDM64GS12L-4

SHEET 5 OF 16

DATE:  
10/9/03

(NOTE 1)

Definition of Operation Voltage(Vop)

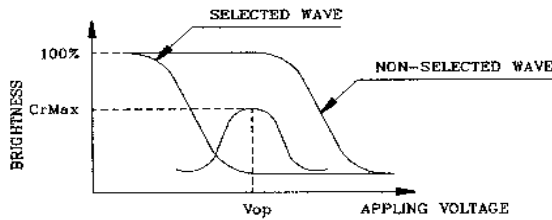

(positive type)

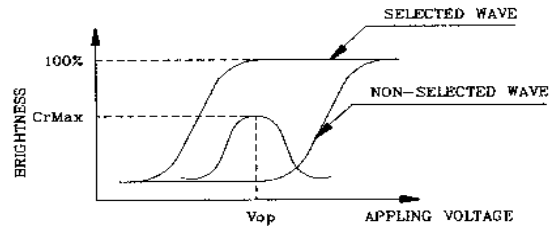

(negative type)

\*Conditions

Viewing Angle : 0  
 Frame Frequency : 70Hz  
 Applying Waveform : 1/N duty 1/a bias

(NOTE 2)

Definition of Response Time(Tr,Tf)

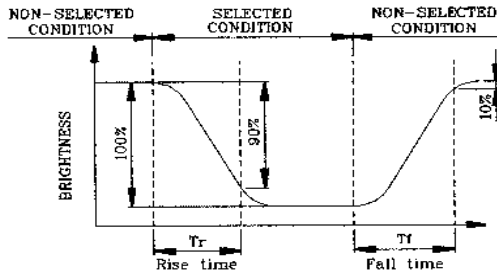

(positive type)

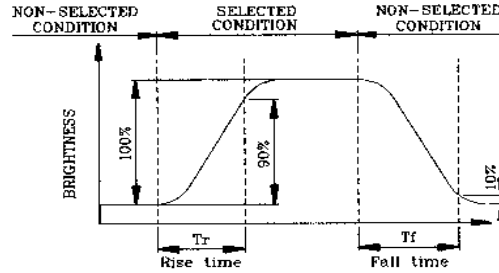

(negative type)

\*Conditions

Operating Voltage : Vop  
 Viewing Angle (θ,φ) : (0,0)  
 Frame Frequency : 70Hz  
 Applying Waveform : 1/N duty 1/a bias

(NOTE 3)

Description of Measuring Equipment and Driving Waveforms

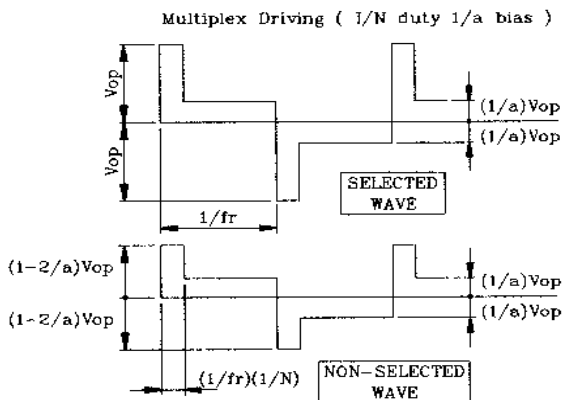
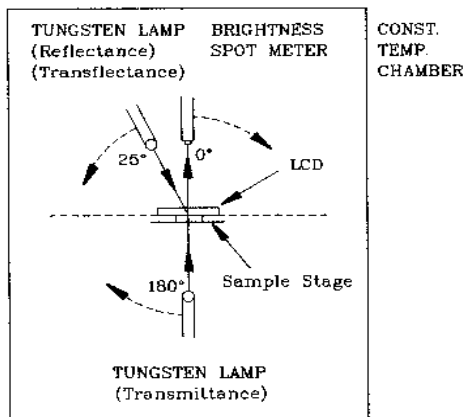

<b>HANTRONIX, INC.</b> 10080 BUBB RD. CUPERTINO, CA 95014	Q.A.:	REV.:	<b>HDM64GS12L-4</b>	SHEET 6 OF 16
	JK	1.2		DATE:

(NOTE 4)

Definition of Viewing Direction

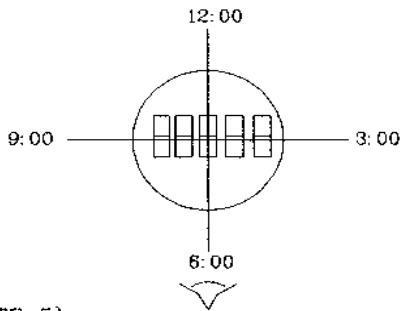

(NOTE 5)

Definition of Viewing Angle

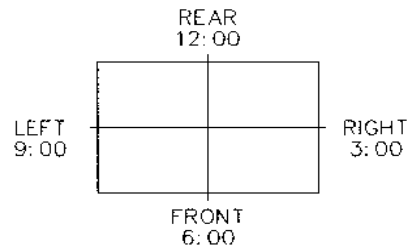
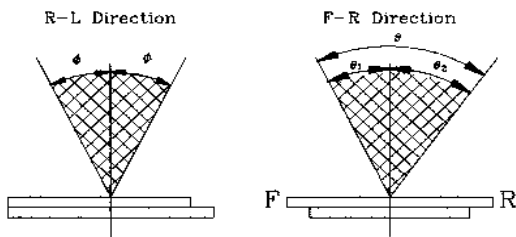

\*For This Product  
The Viewing Direction Is 6 O'clock  
So  $\theta_1 > \theta_2$

$$\theta = \theta_1 + \theta_2$$

\*Conditions

Operating Voltage :  $V_{op}$   
Frame Frequency : 70Hz  
Applying Waveform : 1/N duty 1/a bias  
Contrast Ratio : larger than 2

(NOTE 6)

Definition of Contrast Ratio (Cr)

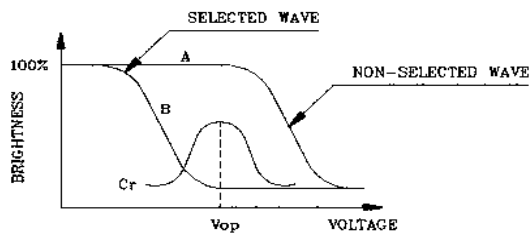

(positive type)

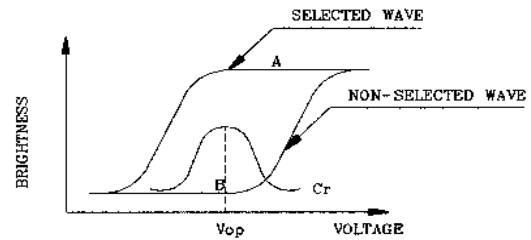

(negative type)

$$\text{Contrast Ratio : } Cr = A/B$$

\*Conditions

Viewing Angle : 0  
Frame Frequency : 70Hz  
Applying Waveform : 1/N duty 1/a bias

HANTRONIX, INC.  
10080 BUBB RD.  
CUPERTINO, CA 95014

Q.A.:  
JK

REV.:  
1.2

HDM64GS12L-4

SHEET 7 OF 16

DATE:  
10/9/03



# 5. BLOCK DIAGRAM

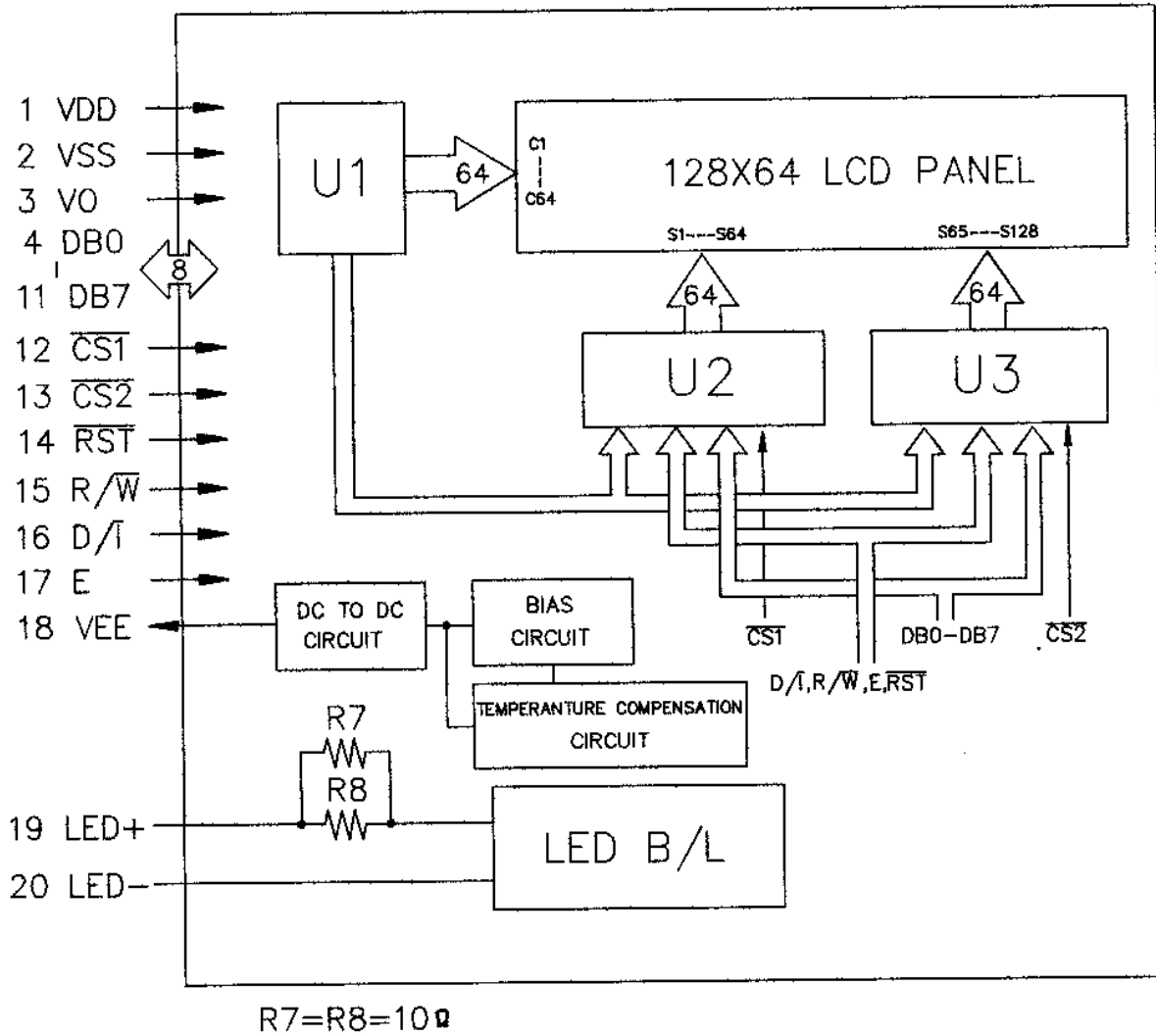

<b>HANTRONIX, INC.</b> 10080 BUBB RD. CUPERTINO, CA 95014	Q.A.:	REV.:	<b>HDM64GS12L-4</b>	SHEET 8 OF 16
	JK	1.2		DATE:

## 6. INTERNAL PIN CONNECTION

PinNo.	Symbol	Level	Function
1	VDD	—	POWER SUPPLY FOR LOGIC CIRCUIT
2	VSS	—	GND
3	VO	—	OPERATING VOLTAGE FOR LCD DRIVING
4	DB0	H/L	(LSB)
5	DB1	H/L	DATA BUS LINE
6	DB2	H/L	
7	DB3	H/L	
8	DB4	H/L	
9	DB5	H/L	
10	DB6	H/L	
11	DB7	H/L	
12	$\overline{CS1}$	L	CHIP SELECTION U2
13	$\overline{CS2}$	L	CHIP SELECTION U3
14	$\overline{RST}$	L	RESET ACTIVE "L"
15	R/W	H/L	H: DATA READ (FROM LCM TO MPU) L: DATA WRITE (FROM MPU TO LCM)
16	D/I	H/L	H: DATA INPUT L: INSTRUCTION CODE INPUT
17	E	H, H→L	ENABLE SIGNAL
18	VEE	—	NEGATIVE VOLTAGE OUTPUT
19	LED(+)	—	ANODE FOR LED BACKLIGHT
20	LED(-)	—	CATHODE FOR LED BACKLIGHT

**HANTRONIX, INC.**  
10080 BUBB RD.  
CUPERTINO, CA 95014

Q.A.:  
JK

REV.:  
1.2

**HDM64GS12L-4**

SHEET 9 OF 16

DATE:  
10/9/03

# 7. POWER SUPPLY

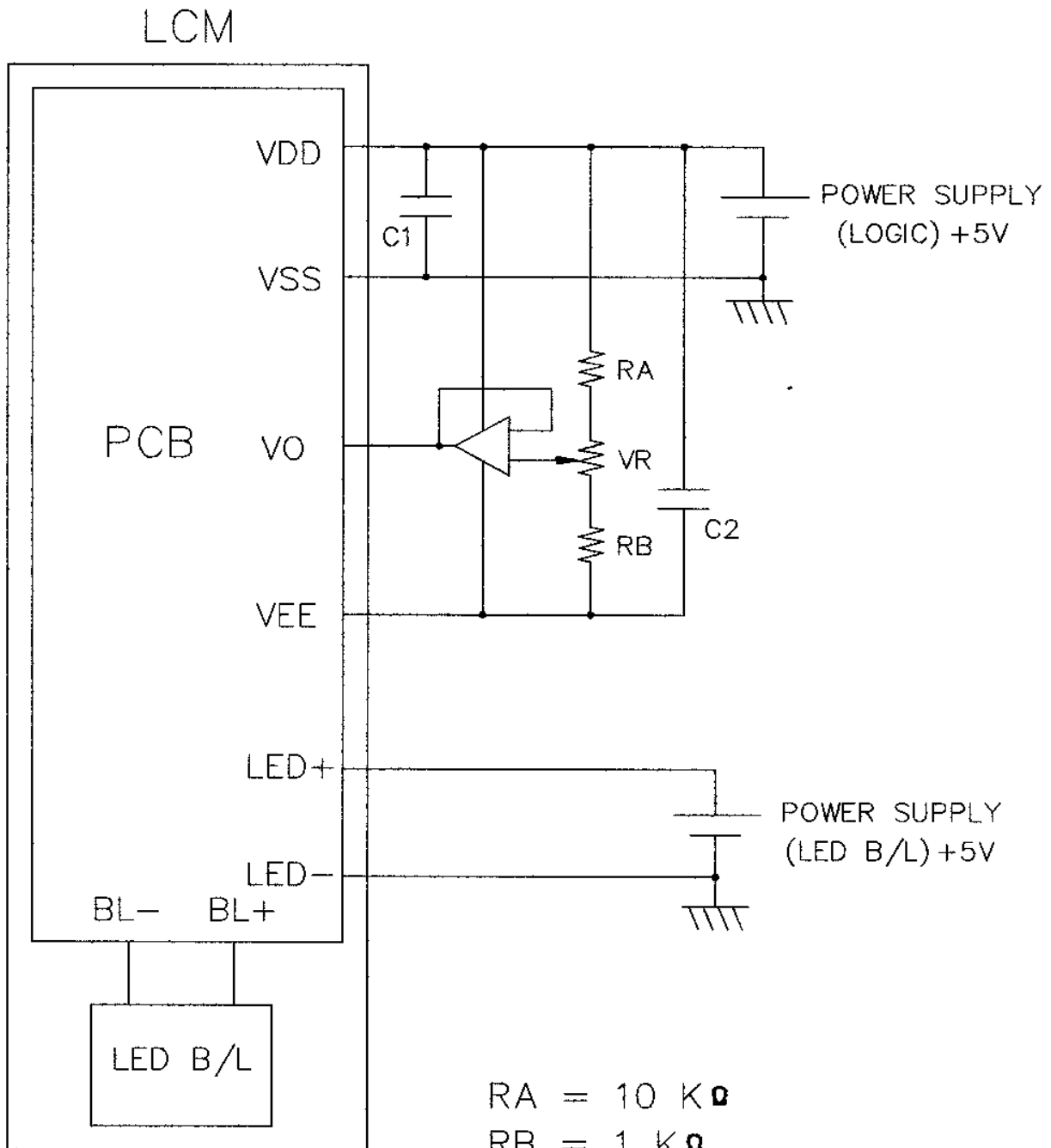

RA = 10 K $\Omega$

RB = 1 K $\Omega$

VR = 10 K $\Omega$ (VARIABLE)

C1,C2 = 10  $\mu$ F

HANTRONIX, INC.  
10080 BUBB RD.  
CUPERTINO, CA 95014

Q.A.:  
JK

REV.:  
1.2

HDM64GS12L-4

SHEET 10 OF 16

DATE:  
10/9/03

# 8. TIMING CHARACTERISTICS

## 8-1 INTERFACE TIMING

Item	Symbol	Test condition	Min.	Typ.	Max.	Unit
Enable cycle time	$t_{\text{ECC}}$	Fig.a , Fig.b	1000	-	-	ns
E high level width	$P_{\text{WEH}}$	Fig.a , Fig.b	450	-	-	ns
E low level width	$P_{\text{WEL}}$	Fig.a , Fig.b	450	-	-	ns
E rise/fall time	$t_r, t_f$	Fig.a , Fig.b	-	-	25	ns
Address set up time	$t_{\text{AS}}$	Fig.a , Fig.b	140	-	-	ns
Address hold time	$t_{\text{AH}}$	Fig.a , Fig.b	10	-	-	ns
Data delay time	$t_{\text{DDR}}$	Fig.b	-	-	320	ns
Data set up time	$t_{\text{DSW}}$	Fig.a	200	-	-	ns
Data hold time (WR)	$t_{\text{DHW}}$	Fig.a	10	-	-	ns
Data hold time (RD)	$t_{\text{DHR}}$	Fig.b	20	-	-	ns

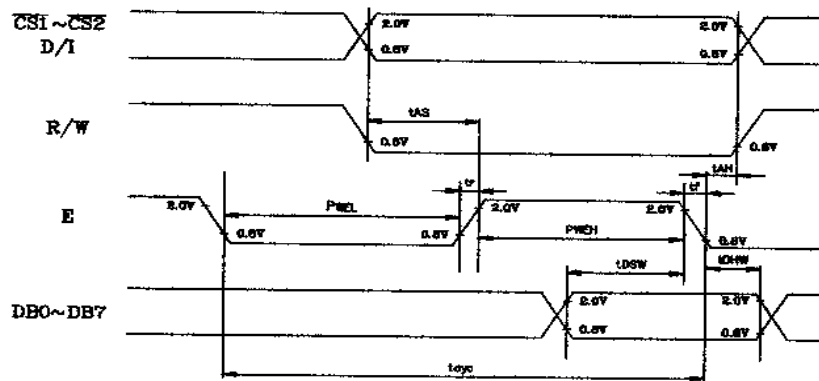

Fig . a Interface timing (data write)

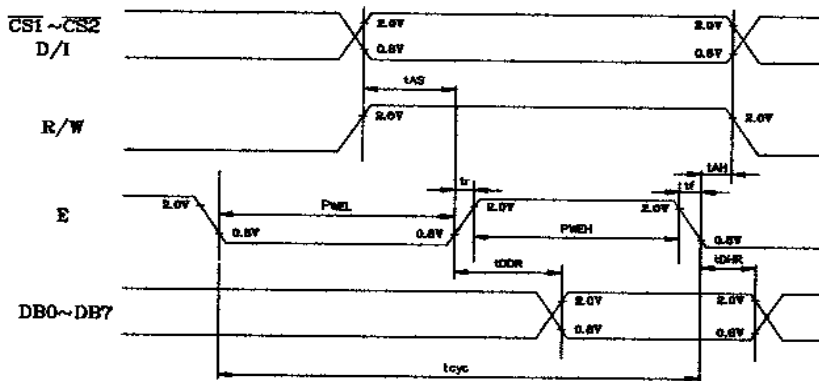

Fig . b Interface timing (data read)

HANTRONIX, INC.  
10080 BUBB RD.  
CUPERTINO, CA 95014

Q.A.:  
JK

REV.:  
1.2

HDM64GS12L-4

SHEET 11 OF 16

DATE:  
10/9/03

# 8-2 DISPLAY PATTERN

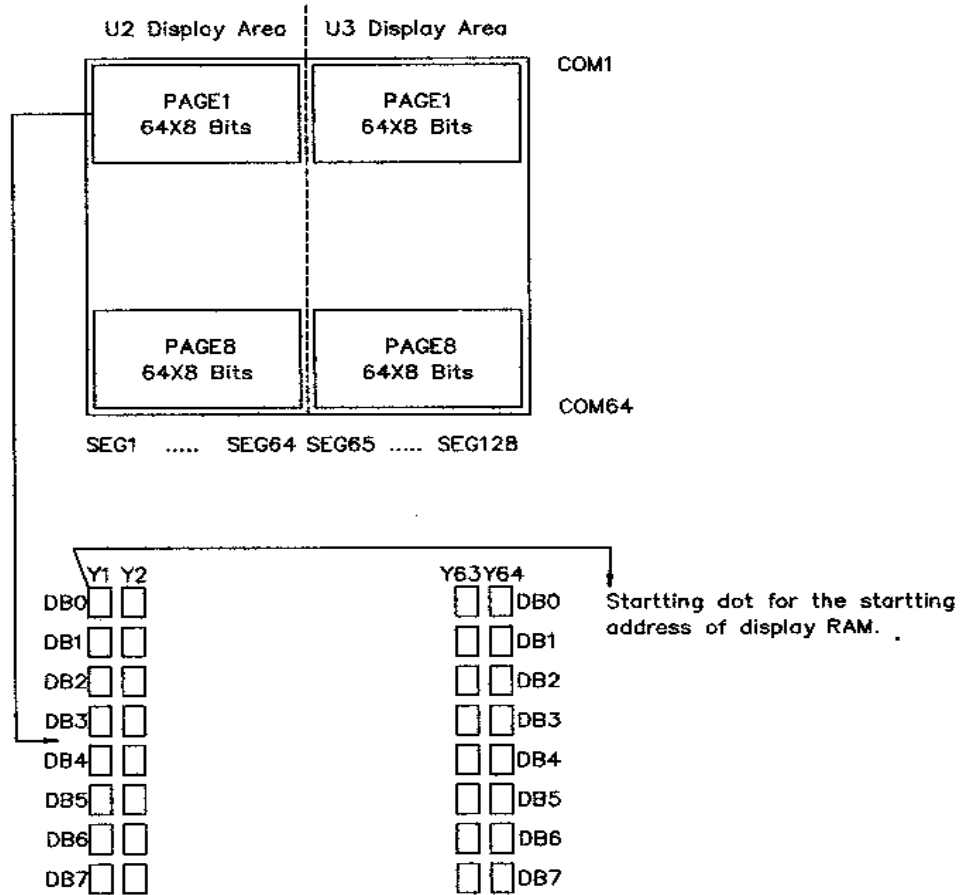

Each segment driver has 8 pages RAM , and each page has 64 x 8 bits RAM .  
 DB0~DB7 are 8 bits transmitted data , where DB0 is LSB and DB7 is MSB .

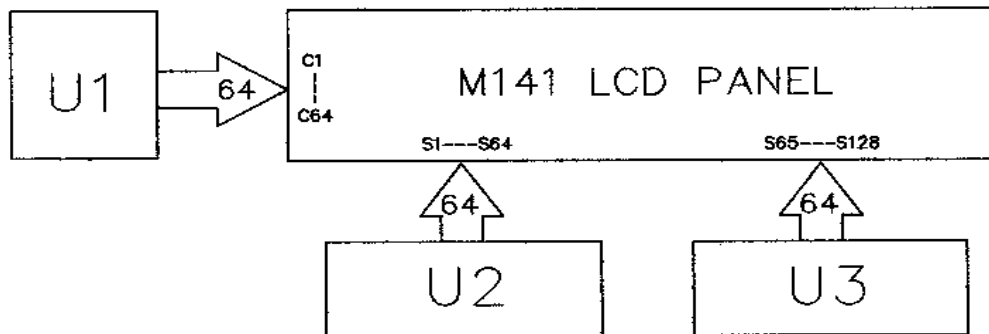

## 8-3 DISPLAY CONTROL INSTRUCTION

The display control instructions control the internal state of the KS0108B. Instructions is received from MPU to HCD61202U for the display control.

Instruction	D/I	R/W	DB7	DB6	DB5	DB4	DB3	DB2	DB1	DB0	FUNCTION
Display ON/OFF	0	0	0	0	1	1	1	1	1	0/1	Controls the display on or off. Internal status and display RAM data is not affected. 0: OFF , 1: ON
Set Address	0	0	0	1	Y address(0~63)						Sets the Y address in the Y address counter.
Set Page (X address)	0	0	1	0	1	1	1	Page(0~7)			Sets the X address at the X address register.
Display Start Line	0	0	1	1	Display start line(0~63)						Indicates the display data RAM displayed at the top of the the screen.
Status Read	0	1	BUSY	0	ON/OFF	RESET	0	0	0	0	Read status. BUSY 0: Ready 1: In operation ON/OFF 0: Display ON 1: Display OFF RESET 0: Normal 1: Reset
Write Display Data	1	0	Write Data								Writes data(DB0:7) into display data RAM. After writing instruction, Y address is increased by 1 automatically.
Read Display Data	1	1	Read Data								Reads data(DB0:7) from display data RAM to the data bus.

HANTRONIX, INC.  
10080 BUBB RD.  
CUPERTINO, CA 95014

Q.A.:  
JK

REV.:  
1.2

HDM64GS12L-4

SHEET 13 OF 16

DATE:  
10/9/03

## 9. RELIABILITY TEST

NO	ITEM	CONDITION			STANDARD	NOTE
1	High Temp. Storing	70°C	120HR		Appearance without defect	
2	Low Temp. Storing	-20°C	120HR		Appearance without defect	
3	High Temp. & High Humi. Storing	40°C 90%RH	120HR		Appearance without defect	
4	Thermal Shock	-20°C,30min→25°C,5min →60°C,30min→25°C,5min (1cycle)			Appearance without defect	5 cycles

**HANTRONIX, INC.**  
10080 BUBB RD.  
CUPERTINO, CA 95014

Q.A.:  
JK

REV.:  
1.2

**HDM64GS12L-4**

SHEET 14 OF 16

DATE:  
10/9/03

(2) NOTE:

• SAFETY

- 1.If the LCD panel breaks, be careful not to get the liquid crystal to touch your skin.
- 2.If the liquid crystal touches your skin or clothes, please wash it off immediately by using soap and water.

• HANDLING

- 1.Avoid static electricity which can damage the CMOS LSI.
- 2.Do not remove the panel or frame from the module.
- 3.The polarizing plate of the display is very fragile. So, please handle it very carefully.
- 4.Do not wipe the polarizing plate with a dry cloth, as it may easily scratch the surface of plate.
- 5.Do not use ketonics solvent & Aromatic solvent, use with a soft cloth soaked with a cleaning naphtha solvent.

• STORAGE

- 1.Store the panel or module in a dark place where the temperature is  $25^{\circ}\text{C}\pm 5^{\circ}\text{C}$  and the humidity is below 65% RH.
- 2.Do not place the module near organics solvents or corrosive gases.
- 3.Do not crush, shake, or jolt the module.

• TERMS OF WARRANT

- 1.Acceptance inspection period  
The period is within one month after the arrival of contracted commodity at the buyer's factory site.
- 2.Applicable warrant period  
The period is within twelve months since the date of shipping out under normal using and storage conditions.

<b>HANTRONIX, INC.</b> 10080 BUBB RD. CUPERTINO, CA 95014	Q.A.: JK	REV.: 1.2	<b>HDM64GS12L-4</b>	SHEET 15 OF 16
				DATE: 10/9/03



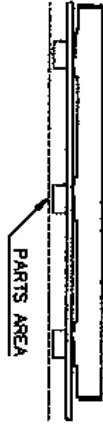
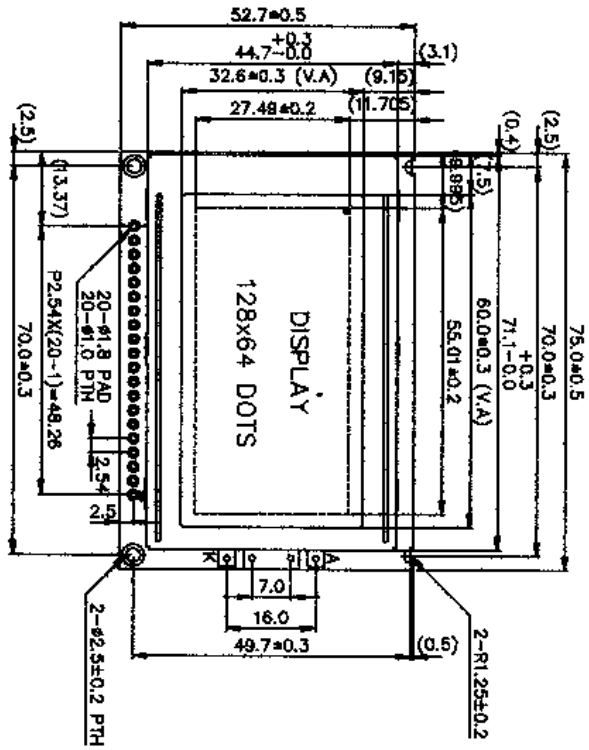

(LED 8/L)

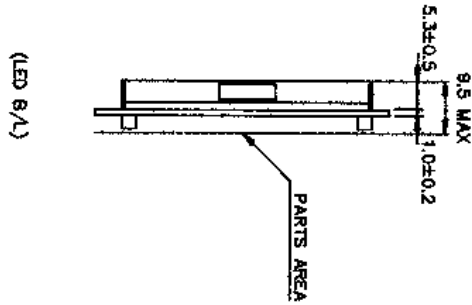

(LED 8/L)

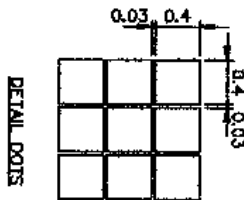

DETAIL DOTS

NOTES :

1. RESOLUTION : 128 x 64 DOTS
2. TEMPERATURE COMPENSATION : BUILT-IN
3. TOLERANCE NO SPECIFIED : ±0.5 mm
4. COB PACKAGE STYLE

<b>HANTRONIX, INC.</b> 10080 BUBB RD. CUPERTINO, CA 95014	Q.A.:	REV.:	<b>HDM64GS12L-4</b>	SHEET 16 OF 16
	JK	1.2		DATE:

# KS0108B

# 64CH SEGMENT DRIVER FOR DOT MATRIX LCD

## INTRODUCTION

The KS0108B is a LCD driver LSI with 64 channel output for dot matrix liquid crystal graphic display system. This device consists of the display RAM, 64 bit data latch 64 bit drivers and decoder logics. It has the internal display RAM for storing the display data transferred from a 8 bit micro controller and generates the dot matrix liquid crystal driving signals corresponding to stored data. The KS0108B composed of the liquid crystal display system in combination with the KS0107B (64 common driver)

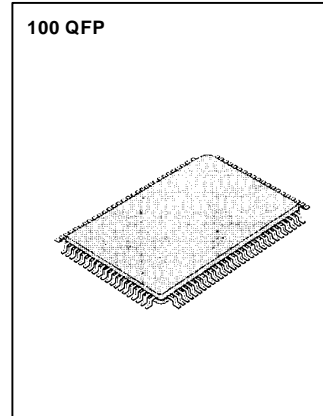

## FEATURES

- Dot matrix LCD segment driver with 64 channel output
- Input and Output signal
  - Input: 8 bit parallel display data
    - Control signal from MPU
    - Splitted bias voltage (V1R, V1L, V2R, V2L, V3R, V3L, V4R, V4L)
  - Output: 64 channel waveform for LCD driving.
- Display data is stored in display data RAM from MPU.
- Interface RAM
  - Capacity: 512 bytes (4096 bits)
  - RAM bit data: RAM bit data = 1:ON  
RAM bit data = 0:OFF
- Applicable LCD duty: 1/32~1/64
- LCD driving voltage: 8V~17V( $V_{DD}-V_{EE}$ )
- Power supply voltage: + 5V±10%

Driver		Controller
COMMON	SEGMENT	
KS0107B	Other KS0108B	MPU

- High voltage CMOS process.
- 100QFP and bare chip available.



**KS0108B**

**64CH SEGMENT DRIVER FOR DOT MATRIX LCD**

**BLOCK DIAGRAM**

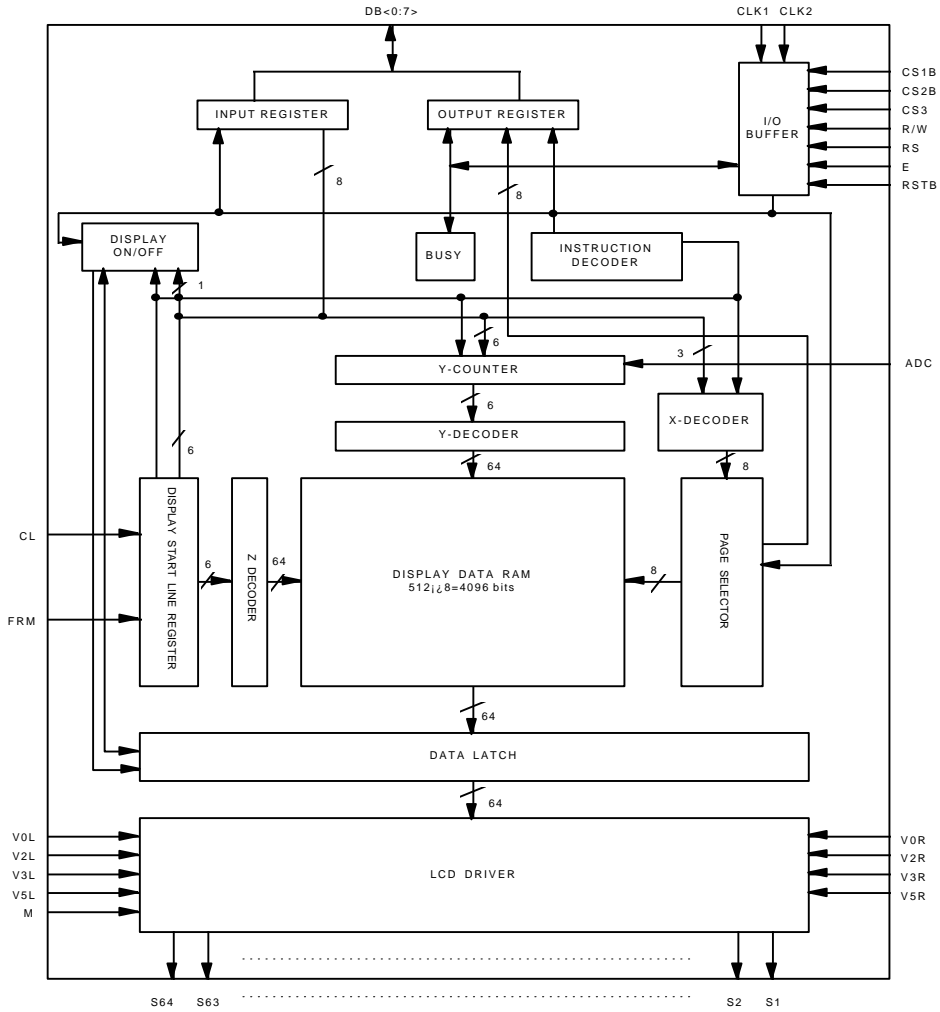

**KS0108B**

**64CH SEGMENT DRIVER FOR DOT MATRIX LCD**

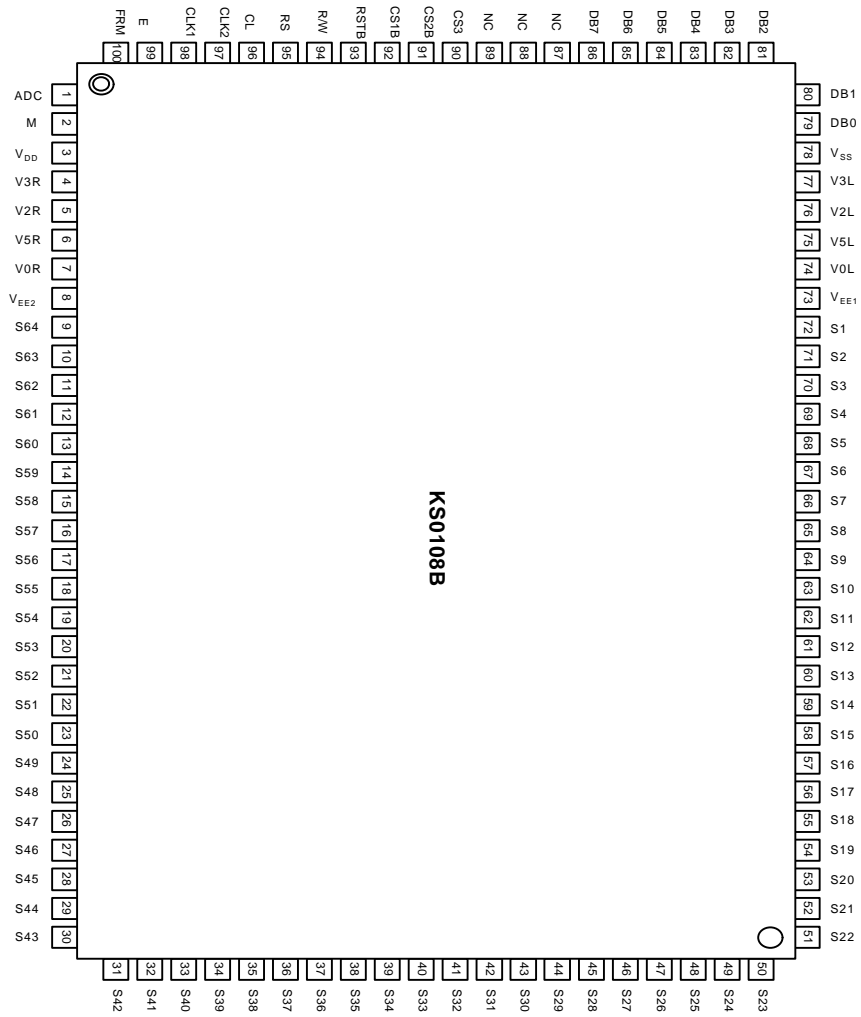

Fig.2. 100QFP Top View

## PIN DESCRIPTION

PIN (NO)	SYMBOL	INPUT/OUTPUT	DESCRIPTION				
3 78 73, 8	V <sub>DD</sub> V <sub>SS</sub> V <sub>EE1,2</sub>	Power	For internal logic circuit (+5V±10%) GND (0V) For LCD driver circuit V <sub>SS</sub> =0V, V <sub>DD</sub> =5V±10% V <sub>DD</sub> -V <sub>EE</sub> =8V~17V V <sub>EE1</sub> and V <sub>EE2</sub> is connected by the same voltage.				
74, 7 76, 5 77, 4 75, 6	V0L, V0R V2L, V2R V3L, V3R V5L, V5R	Power	Bias supply voltage terminals to drive the LCD. <table border="1" style="margin-left: auto; margin-right: auto;"> <tr> <td>Select Level</td> <td>Non-Select Level</td> </tr> <tr> <td>V0L(R), V5L(R)</td> <td>V2L(R), V3L(R)</td> </tr> </table>	Select Level	Non-Select Level	V0L(R), V5L(R)	V2L(R), V3L(R)
Select Level	Non-Select Level						
V0L(R), V5L(R)	V2L(R), V3L(R)						
92 91 90	CS1B CS2B CS3	Input	Chip selection In order to interface data for input or output The terminals have to be CS1B=L, CS2B=L, and CS3=H.				
2	M	Input	Alternating signal input for LCD driving.				
1	ADC	Input	Address control signal of Y address counter. ADC=H→DB<0:7>=0→Y0→S1 DB<0:7>=63→Y63→S64 ADC=L→DB<0:7>=0→Y63→S64 DB<0:7>=63→Y0→S1				
100	FRM	Input	Synchronous control signal. Presets the 6-bit Z counter and synchronizes the common signal with the frame signal when the frame signal becomes high.				
99	E	Input	Enable signal. write mode (R/W=L) → data of DB<0:7> is latched at the falling edge of E. read mode (R/W=H) → DB<0:7> appears the reading data while E is at high level.				
98 97	CLK1 CLK2	Input	2 phase clock signal for internal operation. Used to execute operations for input/output of display RAM data and others.				
96	CL	Input	Display synchronous signal. Display data is latched at rising time of the CL signal and increments the Z-address counter at the CL falling time.				
95	RS	Input	Data or Instruction. RS=H→DB<0:7> : Display RAM Data RS=L→DB<0:7> : Instruction Data				
94	R/W	Input	Read or Write. R/W=H → Data appears at DB<0:7> and can be read by the CPU while E=H, CS1B=L, CS2B=L and CS3=H. R/W=L; Display data DB<0:7> can be written at falling of E when CS1B=L, CS2B=L and CS3=H.				
79~86	DB0~DB7	Input/Output	Data bus. These state I/O common terminal.				

**KS0108B**

**64CH SEGMENT DRIVER FOR DOT MATRIX LCD**

**PIN DESCRIPTION**(continued)

PIN (NO)	NAME	INPUT/OUTPUT	DESCRIPTION													
72~9	S1~S64	Output	LCD Segment driver output. Display RAM data 1:ON Display RAM data 0:OFF (Relation of display RAM data & M) <table border="1" style="margin-left: 20px;"> <thead> <tr> <th>M</th> <th>DATA</th> <th>Output Level</th> </tr> </thead> <tbody> <tr> <td rowspan="2">L</td> <td>L</td> <td>V<sub>2</sub></td> </tr> <tr> <td>H</td> <td>V<sub>0</sub></td> </tr> <tr> <td rowspan="2">H</td> <td>L</td> <td>V<sub>3</sub></td> </tr> <tr> <td>H</td> <td>V<sub>5</sub></td> </tr> </tbody> </table>	M	DATA	Output Level	L	L	V <sub>2</sub>	H	V <sub>0</sub>	H	L	V <sub>3</sub>	H	V <sub>5</sub>
M	DATA	Output Level														
L	L	V <sub>2</sub>														
	H	V <sub>0</sub>														
H	L	V <sub>3</sub>														
	H	V <sub>5</sub>														
93	RSTB	Input	Reset signal. When RSTB=L, (1) ON/OFF register becomes set by 0. (display off) (2) Display start line register becomes set by 0 (Z-address 0 set, display from line 0) After releasing reset, this condition can be changed only by instruction.													
87~89	NC		No connection.(open)													

**MAXIMUM ABSOLUTE LIMIT**

Characteristic	Symbol	Value	Unit	Note
Operating Voltage	V <sub>DD</sub>	-0.3~+7.0	V	*1
Supply Voltage	V <sub>EE</sub>	V <sub>DD</sub> -19.0~V <sub>DD</sub> +0.3	V	*4
Driver Supply Voltage	V <sub>B</sub>	-0.3~V <sub>DD</sub> +0.3	V	*1,3
	V <sub>LCD</sub>	V <sub>EE</sub> -0.3~V <sub>DD</sub> +0.3	V	*2
Operating Temperature	T <sub>OPR</sub>	-30~+85	°C	
Storage Temperature	T <sub>STG</sub>	-55~+125	°C	

\*1. Based on V<sub>SS</sub>=0V.

\*2. Applies the same supply voltage to V<sub>EE1</sub> and V<sub>EE2</sub>. V<sub>LCD</sub>=V<sub>DD</sub>-V<sub>EE</sub>.

\*3. Applies to M, FRM, CL, RSTB, ADC, CLK1, CLK2, CS1B, CS2B, CS3, E, R/W, RS and DB0~DB7.

\*4. Applies V0L(R), V2L(R), V3L(R) and V5L(R).

Voltage level: V<sub>DD</sub>≥V0L=VOR≥V2L=V2R≥V3L=V3R≥V5L=V5R≥V<sub>EE</sub>.



# KS0108B

# 64CH SEGMENT DRIVER FOR DOT MATRIX LCD

## ELECTRICAL CHARACTERISTICS

DC Characteristics (V<sub>DD</sub>=4.5~5.5V, V<sub>SS</sub>=0V, V<sub>DD</sub>-V<sub>EE</sub>=8~17V, T<sub>a</sub>=-30~+85°C)

Characteristic	Symbol	Condition	Min	Typ	Max	Unit	Note
Input High Voltage	V <sub>IH1</sub>	-	0.7V <sub>DD</sub>	-	V <sub>DD</sub>	V	*1
	V <sub>IH2</sub>	-	2.0	-	V <sub>DD</sub>	V	*2
Input Low Voltage	V <sub>IL1</sub>	-	0	-	0.3V <sub>DD</sub>	V	*1
	V <sub>IL2</sub>	-	0	-	0.8	V	*2
Output High Voltage	V <sub>OH</sub>	I <sub>OH</sub> =-200μA	2.4	-	-	V	*3
Output Low Voltage	V <sub>OL</sub>	I <sub>OL</sub> =1.6mA	-	-	0.4	V	*3
Input Leakage Current	I <sub>LKG</sub>	V <sub>IN</sub> =V <sub>SS</sub> ~V <sub>DD</sub>	-1.0	-	1.0	μA	*4
Three-state(OFF) Input Current	I <sub>TSL</sub>	V <sub>IN</sub> =V <sub>SS</sub> ~V <sub>DD</sub>	-5.0	-	5.0	μA	*5
Driver Input Leakage Current	I <sub>DIL</sub>	V <sub>IN</sub> =V <sub>EE</sub> ~V <sub>DD</sub>	-2.0	-	2.0	μA	*6
Operating Current	I <sub>DD1</sub>	During Display	-	-	100	μA	*7
	I <sub>DD2</sub>	During Access Access Cycle=1MHz	-	-	500	μA	*7
On Resistance	R <sub>ON</sub>	V <sub>DD</sub> -V <sub>EE</sub> =15V I <sub>LOAD</sub> =0.1mA	-	-	7.5	KΩ	*8

- \*1. CL, FRM, M, RSTB, CLK1, CLK2
2. CS1B, CS2B, CS3, E, R/W, RS, DB0-DB7
3. DB0-DB7
4. Excepted DB0-DB7
5. DB0-DB7 at High Impedance
6. V0L(R), V2L(R), V3L(R), V5L(R)
7. 1/64 duty, FCLK=250KHZ, Frame Frequency=70HZ, Output: No Load
8. V<sub>DD</sub>-V<sub>EE</sub>=15.5V  
V0L(R)>V2L(R)=V<sub>DD</sub>-2/7 (V<sub>DD</sub>-V<sub>EE</sub>)>V3L(R)=V<sub>EE</sub>+2/7(V<sub>DD</sub>-V<sub>EE</sub>)>V5L(R)

AC Characteristics (V<sub>DD</sub>=5V±10%, V<sub>SS</sub>=0V, T<sub>a</sub>=-30°C~+85°C)

### (1) Clock Timing

Characteristic	Symbol	Min	Typ	Max	Unit
CLK1, CLK2 Cycle Time	t <sub>CY</sub>	2.5	-	20	μS
CLK1 'LOW' Level Width	t <sub>WL1</sub>	625	-	-	ns
CLK2 'LOW' Level Width	t <sub>WL2</sub>	625	-	-	
CLK1 'HIGH' Level Width	t <sub>WH1</sub>	1875	-	-	
CLK2 'HIGH' Level Width	t <sub>WH2</sub>	1875	-	-	
CLK1-CLK2 Phase Difference	t <sub>D12</sub>	625	-	-	
CLK2-CLK1 Phase Difference	t <sub>D21</sub>	625	-	-	
CLK1, CLK2 Rise Time	t <sub>R</sub>	-	-	150	
CLK1, CLK2 Fall Time	t <sub>F</sub>	-	-	150	



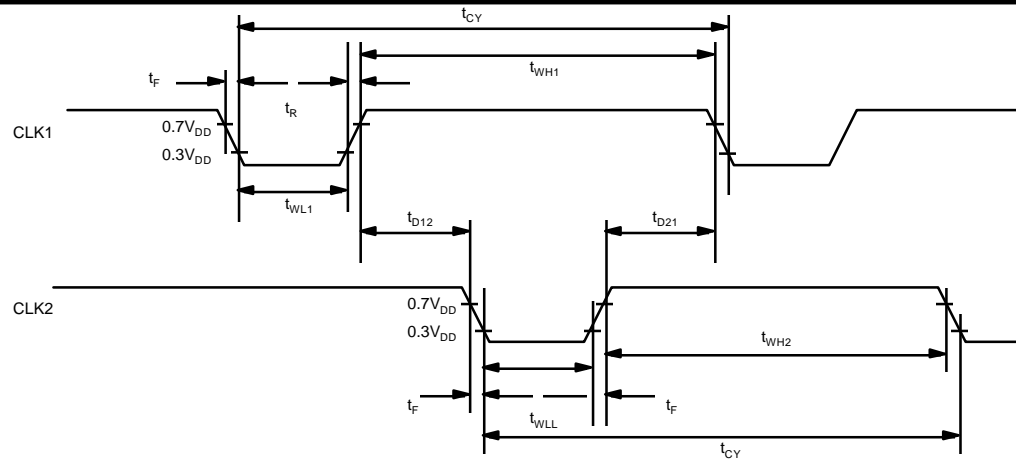

Fig 1. External clock waveform

(2) Display Control Timing

Characteristic	Symbol	Min	Typ	Max	Unit
FRM Delay Time	$t_{DF}$	-2	-	+2	us
M Delay Time	$t_{DM}$	-2	-	+2	us
CL 'LOW' Level Width	$t_{WL}$	35	-	-	us
CL 'HIGH' Level Width	$t_{WH}$	35	-	-	us

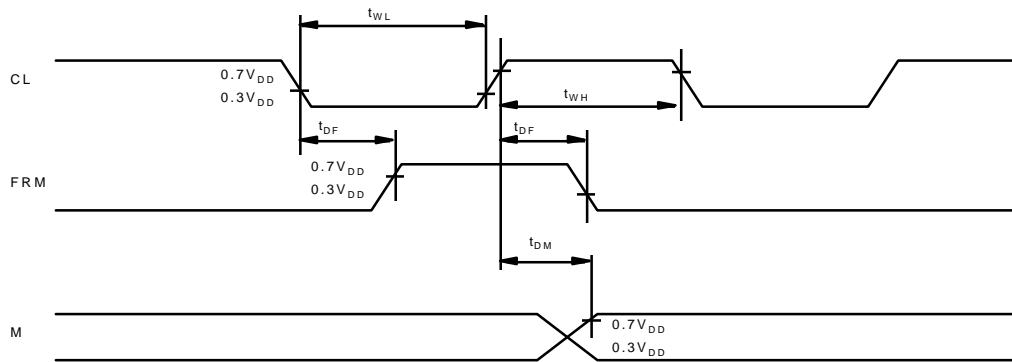

Fig 2. Display control signal waveform



(3) MPU Interface

Chatacteristic	Symbol	Min	Typ	Max	Unit
E Cycle	$t_c$	1000	-	-	ns
E High Level Width	$t_{WH}$	450	-	-	ns
E Low Level Width	$t_{WL}$	450	-	-	ns
E Rise Time	$t_R$	-	-	25	ns
E Fall Time	$t_F$	-	-	25	ns
Address Set-Up Time	$t_{ASU}$	140	-	-	ns
Address Hold Time	$t_{AH}$	10	-	-	ns
Data Set-Up Time	$t_{DSU}$	200	-	-	ns
Data Delay Time	$t_D$	-	-	320	ns
Data Hold Time (Write)	$t_{DHW}$	10	-	-	ns
Data Hold Time (Read)	$t_{DHR}$	20	-	-	ns

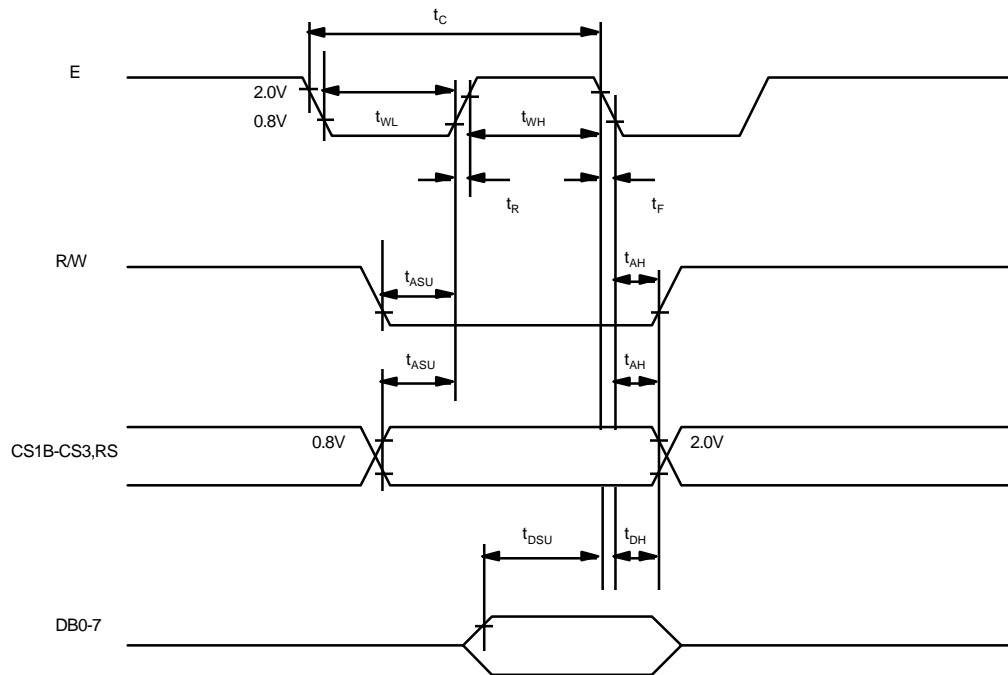

Fig 3. MPU write timing

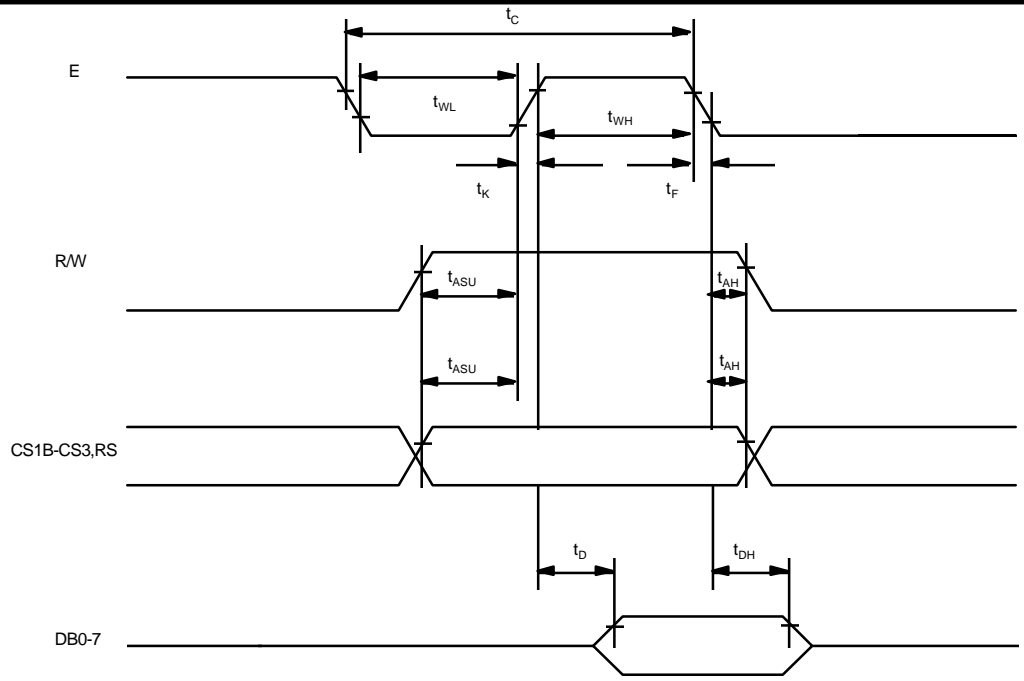

Fig 3. MPU write timing

# KS0108B

# 64CH SEGMENT DRIVER FOR DOT MATRIX LCD

## APPLICATION CIRCUIT

1.1/64 duty common driver(KS0107B) interface circuit

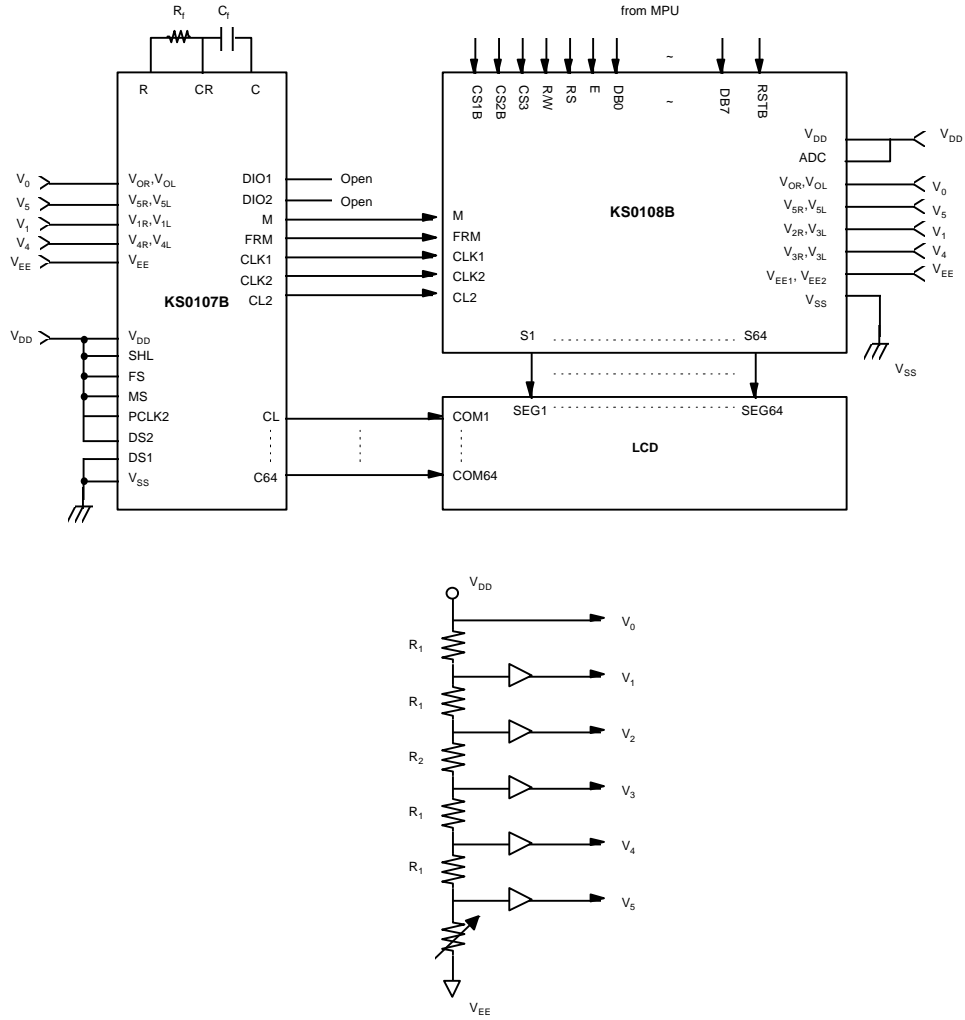

**OPERATING PRINCIPLES & METHODS**

**1. I/O Buffer**

Input buffer controls the status between the enable and disable of chip. Unless the CS1B to CS3 is in active mode, Input or output of data and instruction does not execute. Therefore internal state is not change. But RSTB and ADC can operate regardless CS1B-CS3.

**2. Input register**

Input register is provided to interface with MPU which is different operating frequency. Input register stores the data temporarily before writing it into display RAM.

When CS1B to CS3 are in the active mode, R/W and RS select the input register. The data from MPU is written into input register. Then Writing it into display RAM. Data latched for falling of the E signal and write automatically into the display data RAM by internal operation.

**3. Output register**

Output register stores the data temporarily from display data RAM when CS1B, CS2B, CS3 is in active mode and R/W and RS=H, stored data in display data RAM is latched in output register. When CS1B to CS3 is in active mode and R/W=H, RS=L, status data (busy check) can read out.

To read the contents of display data RAM, twice access of read instruction is needed. In first access, data in display data RAM is latched into output register. In second access, MPU can read data which is latched. That is, to read the data in display data RAM, it needs dummy read. But status read is not needed dummy read.

RS	R/W	Function
L	L	Instruction
	H	Status read (busy check)
H	L	Data write (from input register to display data RAM)
	H	Data read (from display data RAM to output register)

**4. Reset**

Reset can be initialized system by setting RSTB terminal at low level when turning power on, receiving instruction from MPU. When RSTB becomes low, following procedure is occurred.

1. Display off
2. Display start line register become set by 0.(Z-address 0)

While RSTB is low, any instruction except status read can be accepted. Reset status appears at DB4. After DB4 is low, any instruction can be accepted.

The Conditions of power supply at initial power up are shown in table 1.

Table 1. Power Supply Initial Conditions

Item	Symbol	Min	Typ	Max	Unit
Reset Time	$t_{RS}$	1.0	-	-	us
Rise Time	$t_R$	-	-	200	ns

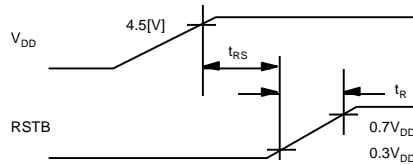

**5. Busy flag**

Busy flag indicates that KS0108B is operating or no operating. When busy flag is high, KS0108B is in internal operating. When busy flag is low, KS0108B can accept the data or instruction.  
DB7 indicates busy flag of the KS0108B.

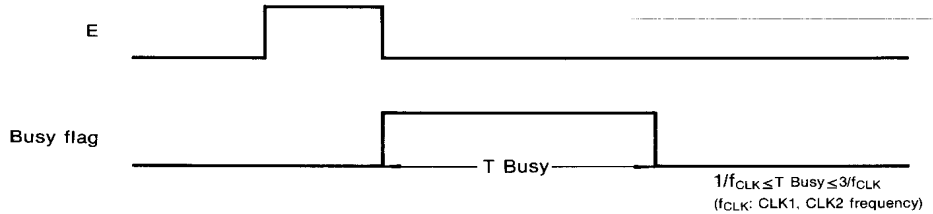
**6. Disp**

The display on/off flip-flop makes on/off the liquid crystal display. When flip-flop is reset (logical low), selective voltage or non selective voltage appears on segment output terminals. When flip-flop is set (logic high), non selective voltage appears on segment output terminals regardless of display RAM data.

The display on/off flip-flop can changes status by instruction. The display data at all segment disappear while RSTB is low.

The status of the flip-flop is output to DB5 by status read instruction.

The display on/off flip-flop synchronized by CL signal.

**7. X Page Register**

X page register designates page of the internal display data RAM.

It has not count function. An address is set by instruction.

**8. Y address counter**

Y address counter designates address of the internal display data RAM. An address is set by instruction and is increased by 1 automatically by read or write operations of display data.

**9. Display Data RAM**

Display data RAM stores a display data for liquid crystal display. To express on state dot matrix of liquid crystal display, write data 1. The other way, off state writes 0.

Display data RAM address and segment output can be controlled by ADC signal.

ADC= $H_{\phi_i}$  DB<0:7>=0 - Y-address 0 - A0 - S1

DB<0:7>=63 - Y-address 63 - A63 - S64

ADC= $L_{\phi_i}$  DB<0:7>=0 ~ Y-address 63 - A63 - S64

DB<0:7>=63 ~ A0 - S1

ADC terminal connect the  $V_{DD}$  or  $V_{SS}$ .

**10. Display Start Line Register**

The display start line register indicates of display data RAM to display top line of liquid crystal display.

Bit data (DB<0:5>) of the display start line set instruction is latched in display start line register. Latched data is transferred to the Z address counter while FRM is high, presetting the Z address counter.

It is used for scrolling of the liquid crystal display screen.

---

**DISPLAY CONTROL INSTRUCTION**

The display control instructions control the internal state of the KS0108B. Instruction is received from MPU to KS0108B for the display control. The following table shows various instructions.

Instruction	RS	R/W	DB7	DB6	DB5	DB4	DB3	DB2	DB1	DB0	Function
Display ON/OFF	L	L	L	L	H	H	H	H	H	L/H	Controls the display on or off. Internal status and display RAM data is not affected. L:OFF, H:ON
Set Address	L	L	L	H	Y address (0~63)					Settings the Y address in the Y address counter.	
Set Page ( X address)	L	L	H	L	H	H	H	Page (0~7)			Sets the X address at the X address register.
Display Start Line	L	L	H	H	Display start line (0~63)					Indicates the display data RAM displayed at the top of the screen.	
Status Read	L	H	B U S Y	L	O N / O F F	R E S E T	L	L	L	L	Read status. BUSY L: Ready H: In operation ON/OFF L: Display ON H: Display OFF RESET L: Normal H: Reset
Write Display Data	H	L	Write Data								Writes data (DB0:7) into display data RAM. After writing instruction, Y address is increased by 1 automatically.
Read Display Data	H	H	Read Data								Reads data (DB0:7) from display data RAM to the data bus.

2. Timing diagram (1/64 duty)

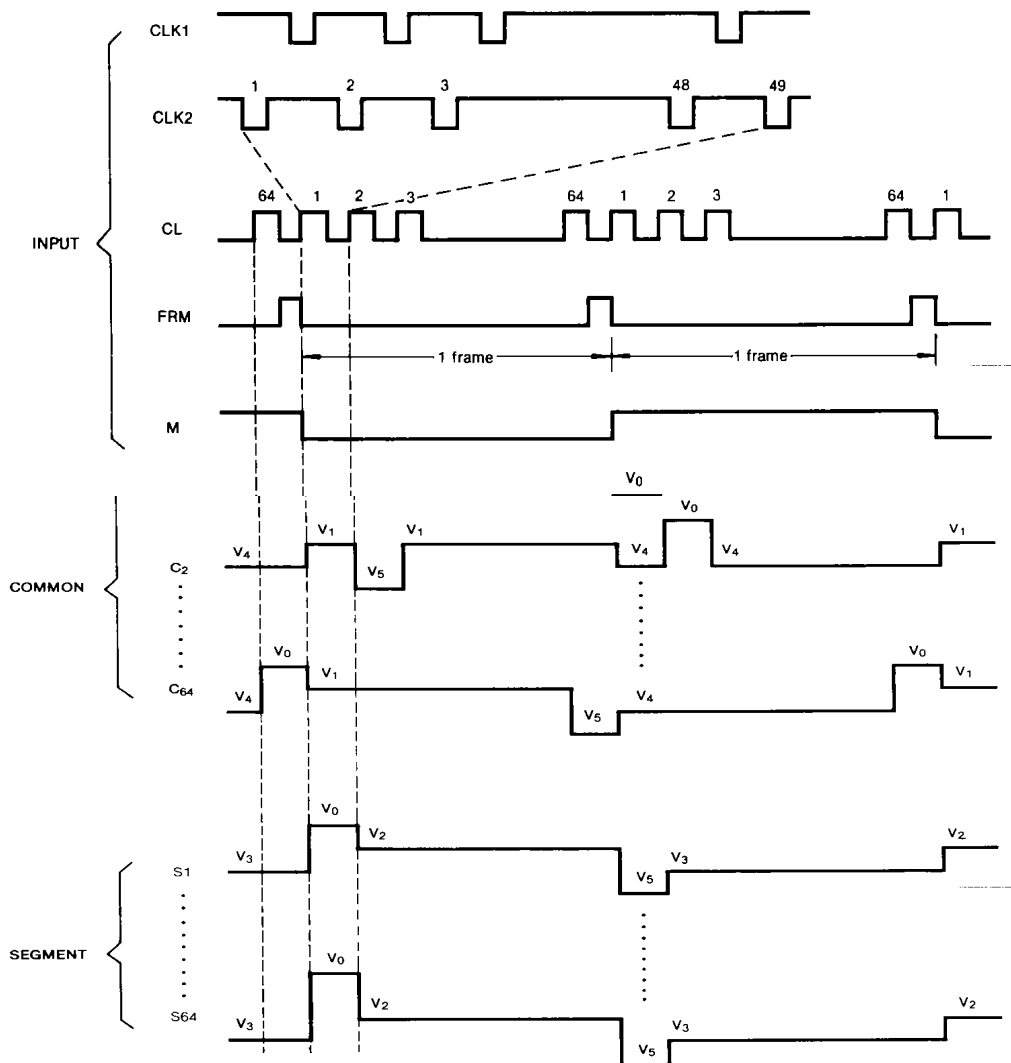

3. LCD Panel interface application circuit

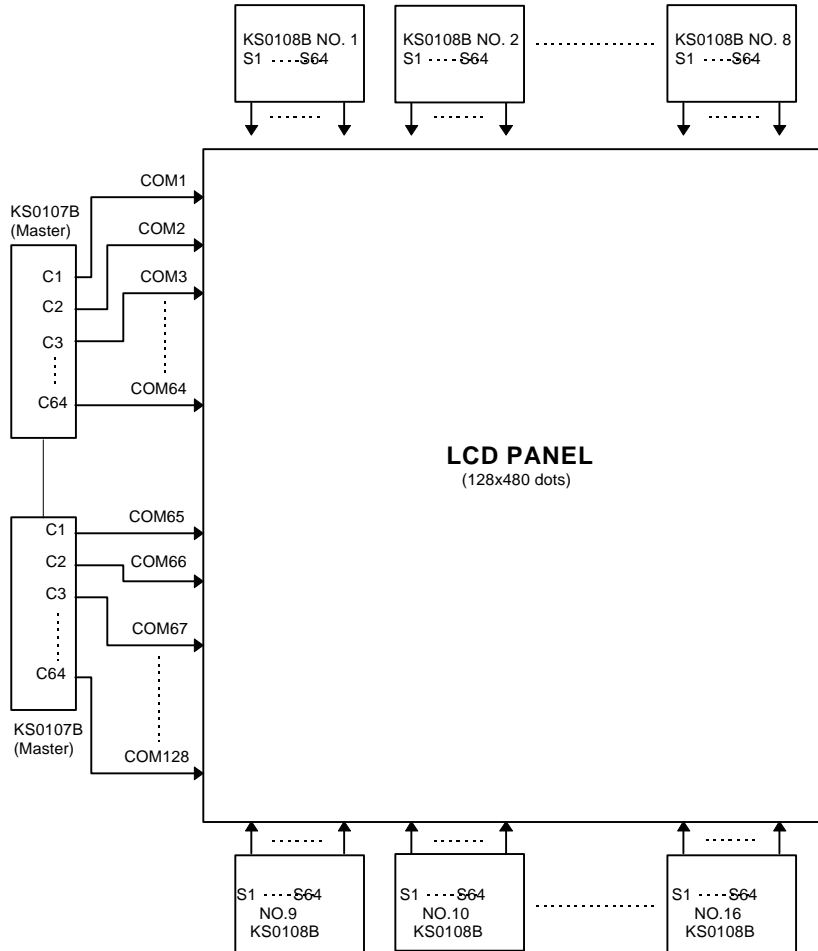



# KS0108B

# 64CH SEGMENT DRIVER FOR DOT MATRIX LCD

## PAD DIAGRAM

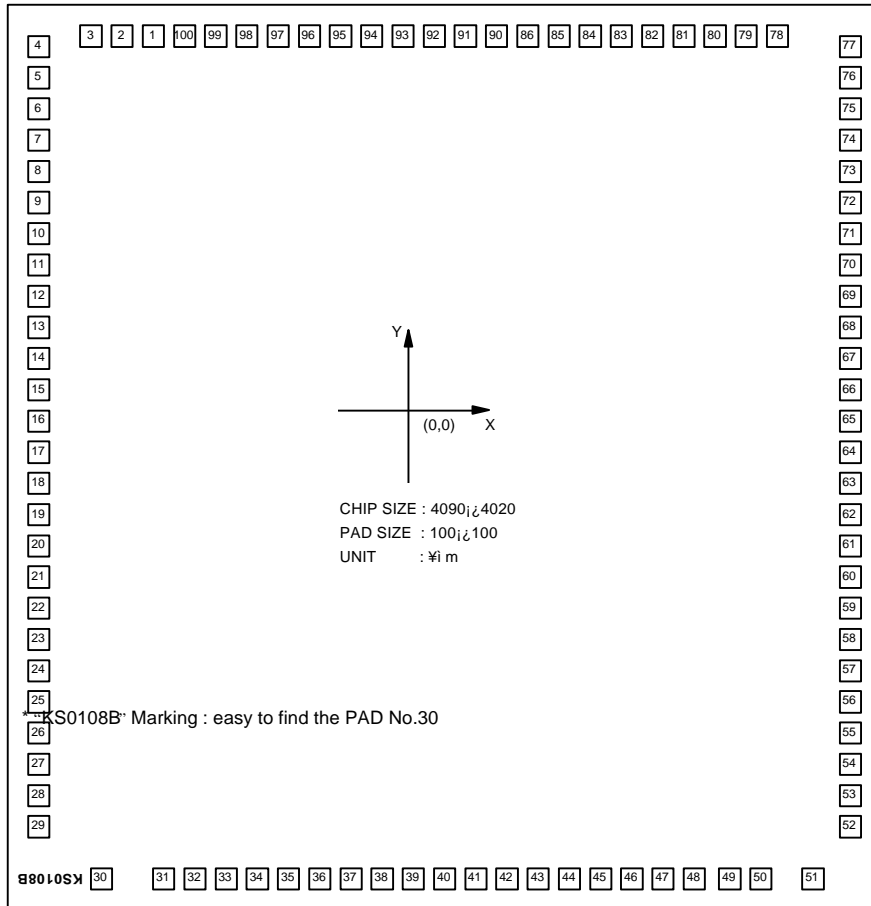

## PAD LOCATION

PAD NUMBER	PAD NAME	COORDINATE		PAD NUMBER	PAD NAME	COORDINATE		PAD NUMBER	PAD NAME	COORDINATE	
		X	Y			X	Y			X	Y
1	ADC	-1140	1845	35	S38	-687	-1845	69	S4	1882	791
2	M	-1275	1845	36	S37	-562	-1845	70	S3	1882	916
3	VDD	-1410	1845	37	S36	-437	-1845	71	S2	1882	1041
4	V3R	-1882	1809	38	S35	-312	-1845	72	S1	1882	1166
5	V2R	-1882	1684	39	S34	-187	-1845	73	VEE1	1882	1310
6	V5R	-1882	1559	40	S33	62	-1845	74	V0L	1882	1435
7	V0R	-1882	1434	41	S32	62	-1845	75	V5L	1882	1559
8	VEE2	-1882	1309	42	S31	187	-1845	76	V2L	1882	1684
9	S64	-1882	1165	43	S30	312	-1845	77	V3L	1882	1809
10	S63	-1882	1040	44	S29	437	-1845	78	VSS	1412	1845
11	S62	-1882	915	45	S28	562	-1845	79	DB0	1277	1845
12	S61	-1882	790	46	S27	687	-1845	80	DB1	1142	1845
13	S60	-1882	665	47	S26	812	-1845	81	DB2	1007	1845
14	S59	-1882	540	48	S25	937	-1845	82	DB3	882	1845
15	S58	-1882	415	49	S24	1062	-1845	83	DB4	757	1845
16	S57	-1882	290	50	S23	1187	-1845	84	DB5	632	1845
17	S56	-1882	165	51	S22	1487	-1845	85	DB6	507	1845
18	S55	-1882	40	52	S21	1882	-1379	86	DB7	382	1845
19	S54	-1882	-84	53	S20	1882	-1239	87		NC	
20	S53	-1882	-209	54	S19	1882	-1099	88		NC	
21	S52	-1882	-334	55	S18	1882	-959	89		NC	
22	S51	-1882	-459	56	S17	1882	-834	90	CS3	245	1845
23	S50	-1882	-584	57	S16	1882	-709	91	CS2B	120	1845
24	S49	-1882	-709	58	S15	1882	-584	92	CSTB	-5	1845
25	S48	-1882	-834	59	S14	1882	-459	93	RSTB	-130	1845
26	S47	-1882	-959	60	S13	1882	-334	94	RAW	-255	1845
27	S46	-1882	-1099	61	S12	1882	-209	95	RS	-380	1845
28	S45	-1882	-1239	62	S11	1882	-84	96	CL	-505	1845
29	S44	-1882	-1379	63	S10	1882	41	97	CLK2	-630	1845
30	S43	-1487	-1845	64	S9	1882	166	98	CLK1	-755	1845
31	S42	-1187	-1845	65	S8	1882	291	99	E	-880	1845
32	S41	-1062	-1845	66	S7	1882	416	100	FRM	-1005	1845
33	S40	-937	-1845	67	S6	1882	541				
34	S39	-812	-1845	68	S5	1882	666				

# Interfacing a Hantronix 128x64 Graphic Module to an 8-bit Microcontroller

## Introduction:

Due to its thin profile, light weight, low power consumption and easy handling, liquid crystal graphic display modules are used in a wide variety of applications. This note details a simple interface technique between a Hantronix HDM64GS12 and a micro-controller. The HDM64GS12 has a built-in Hitachi HD61202, or Samsung KS107, controller which performs all of the refreshing and data storage tasks of the LCD display. This note applies to any display using these controllers. The driving micro-controller is the popular 87C751.

The display is split logically in half. It contains two controllers with controller #1 (Chip select 1) controlling the left half of the display and controller #2 (Chip select 2) controlling the right half. Each controller must be addressed independently.

The page addresses, 0-7, specify one of the 8 horizontal pages which are 8 bits (1 byte) high. A drawing of the display and how it is mapped to the refresh memory is shown below.

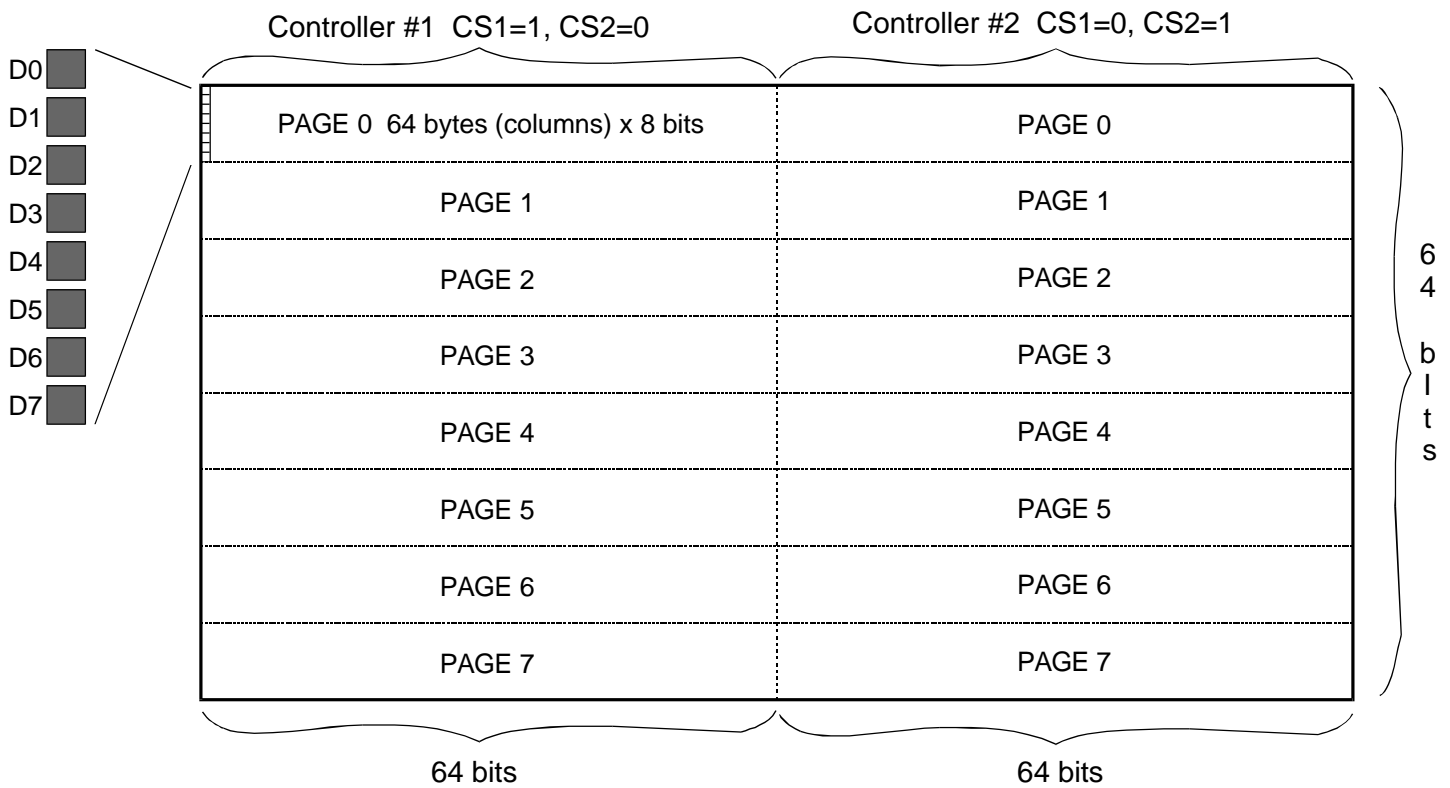

The schematic on page two is a simple circuit to illustrate one possible interface scheme. This is the circuit that the code example will work with directly.

Schematic Diagram:

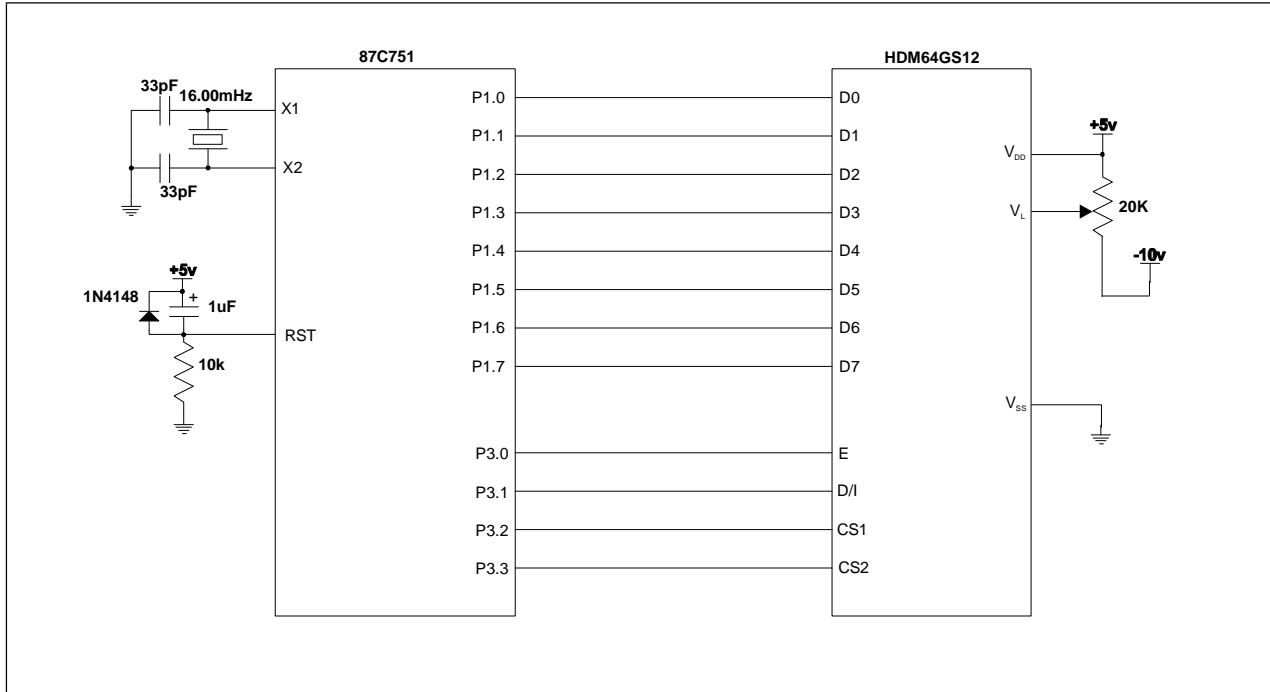

The following software is in 8051 assembly language and will run as-is on the hardware shown above. The busy status flag is not tested in this software. It is usually not necessary to do so when the display module is connected to the processor via I/O lines. When the module is connected to the processor's data bus and mapped into it's memory area the status should be tested to guarantee reliable service.

Displayed Pattern:

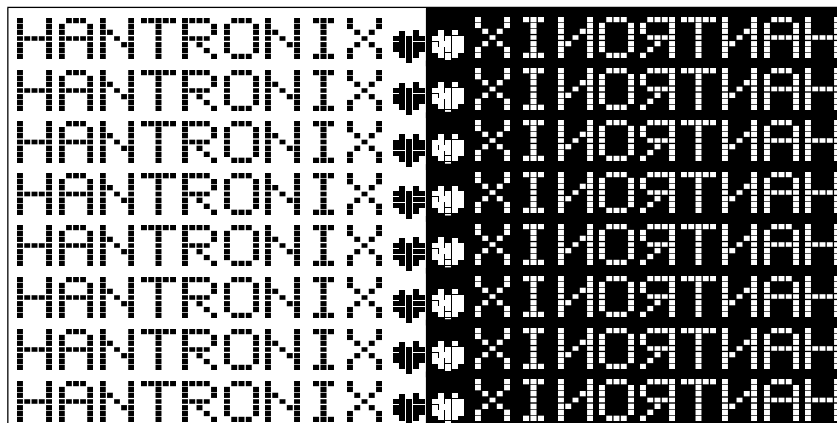

Software Flowchart:

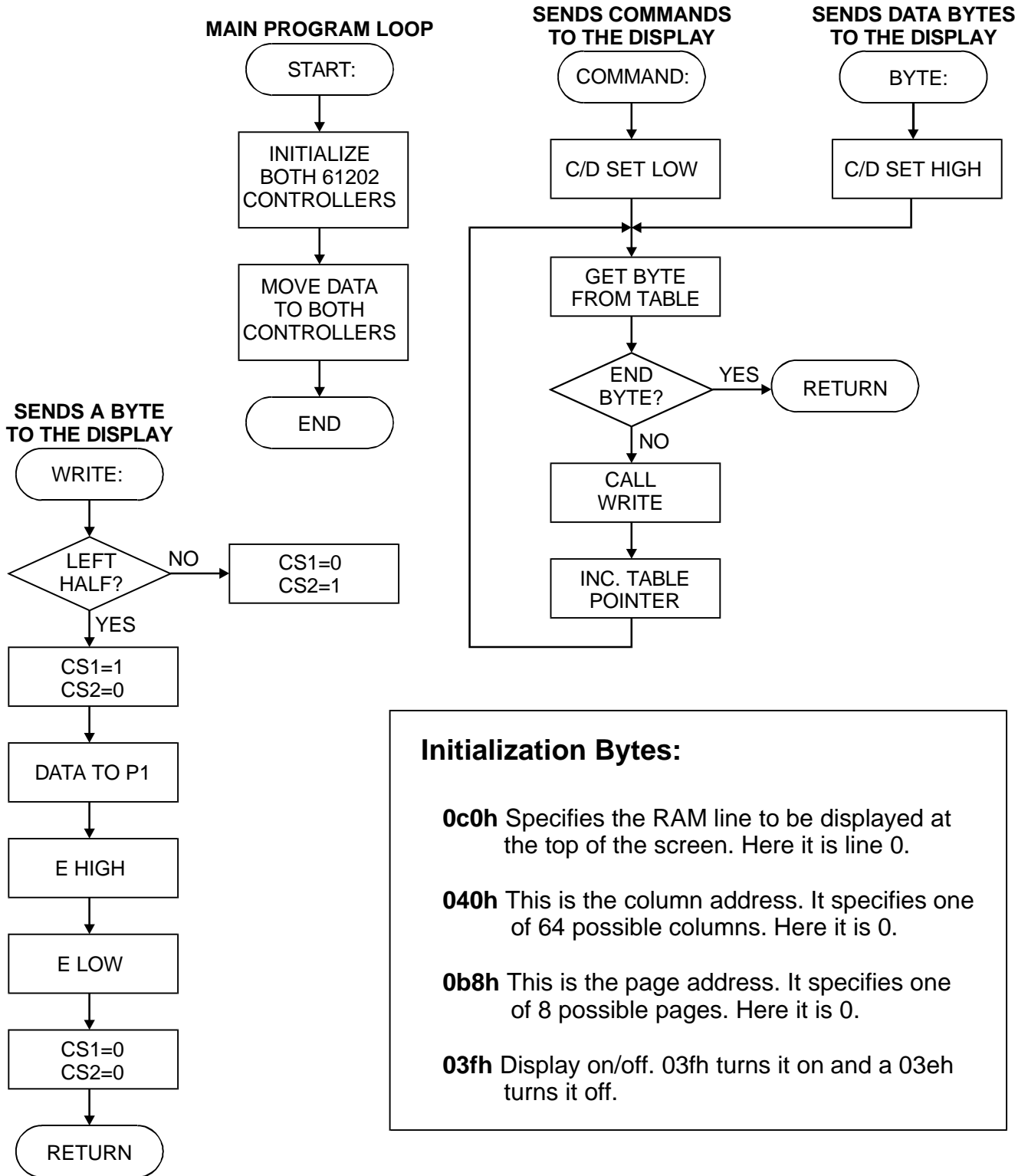

### Software Source Code:

```

$MOD751
; *****
; *
; *      HD61202 Application Note V1.0      *
; *
; *****

; The processor clock speed is 16MHz.
; Cycle time is .750ms.
; HD61202 demo software to display
; the Hantronix logo on a 128 x 64 LCD.

        org     00h
        ljmp    start

        org     100h

; Initialize the 64gs12

Start:
        mov     p3,#00
        mov     r0,#00h      ;set 64gs12 left
        mov     dptr,#msg11  ;initialization bytes
        lcall   command
        mov     r0,#01h      ;set 64gs12 right
        mov     dptr,#msg11  ;initialization bytes
        lcall   command

; Display pattern

        mov     r4,#0b8h     ;page command
        mov     r5,#08h;    ;page count

Loop1:
        mov     r0,#00h      ;set 64gs12 left
        mov     dptr,#msg11
        lcall   byte
        clr     p3.1         ;set command
        inc     r4           ;bump page add
        mov     a,r4
        mov     r1,a
        lcall   write
        djnz   r5,loop1     ;repeat 8 times
        mov     r4,#0b8h     ;page add. Command
        mov     r5,#8h      ;page count

Loop2:
        mov     r0,#01h      ;set 64gs12 right
        mov     dptr,#msg1r
        lcall   byte
        clr     p3.1         ;set command
        inc     r4           ;bump page add
        mov     a,r4
        mov     r1,a
        lcall   write
        djnz   r5,loop2     ;repeat 8 times
        sjmp   $           ;end
    
```

```

; *****
; SUBROUTINES
; *****

; COMMAND sends the byte pointed to by
; the DPTR to the graphics module
; as a series of commands.

Command:
        clr     p3.1         ;set command

Command2:
        clr     a
        movc   a,@+dptr     ;get byte
        cjne   a,#099h,command1 ;done?
        Ret

Command1:
        mov     r1,a
        lcall   write       ;send it
        inc     dptr
        sjmp   command2

; BYTE sends the byte pointed to by
; the DPTR to the graphics module
; as a series of data bytes.

Byte:
        setb   p3.1         ;set data
        sjmp   command2

; WRITE sends the byte in R1 to the
; display.

Write:
        mov     a,r0         ;CS the display
        jnz    writel       ;right half
        setb   p3.2         ;left half

Write2:
        mov     p1,r1       ;get data
        setb   p3.0         ;strobe it
        Nop
        clr    p3.0
        clr    p3.2         ;de-select module
        clr    p3.3
        Ret

Writel:
        setb   p3.3
        sjmp   write2
    
```

```
*****
; TABLES AND DATA

; Initialization bytes
Msgil:
    db      0c0h,40h,0b8h,3fh,99h

; "Hantronix", left half

Msgil:
    db      0,0feh,10h,10h,10h,0feh,0      ;H
    db      0fch,12h,12h,12h,0fch,0      ;A
    db      0feh,08h,10h,20h,0feh,0      ;N
    db      02h,02h,0feh,02h,02h,0      ;T
    db      0feh,12h,32h,52h,8ch,0      ;R
    db      7ch,82h,82h,82h,7ch,0      ;O
    db      0feh,08h,10h,20h,0feh,0      ;N
    db      0,0,82h,0feh,82h,0      ;I
    db      0,0c6h,28h,10h,28h,0c6h,0      ;X
    db      0,38h,7ch,0f8h,7ch,38h,0      ;heart
    db      0,99h

; "Hantronix", right half (reverse video)

Msglr:
    db      0ffh,0c7h,83h,07h,83h,0c7h,0ffh      ;heart
    db      0ffh,39h,0d7h,0efh,0d7h,39h,0ffh      ;X
    db      0ffh,0ffh,7dh,01h,7dh,0ffh      ;I
    db      01h,0dfh,0efh,0f7h,01h,0ffh      ;N
    db      83h,7dh,7dh,7dh,83h,0ffh      ;O
    db      073h,0adh,0cdh,0edh,01h,0ffh      ;R
    db      0fdh,0fdh,01h,0fdh,0fdh,0ffh      ;T
    db      01h,0dfh,0efh,0f7h,01h,0ffh      ;N
    db      03h,0edh,0edh,0edh,03h,0ffh      ;A
    db      0ffh,01h,0efh,0efh,0efh,01h,0ffh      ;H
    db      0ffh,99h

end
```

# HDM 64GS12L-4

## Dimensional Drawing

128 X 64 Dots Graphic, Small Size

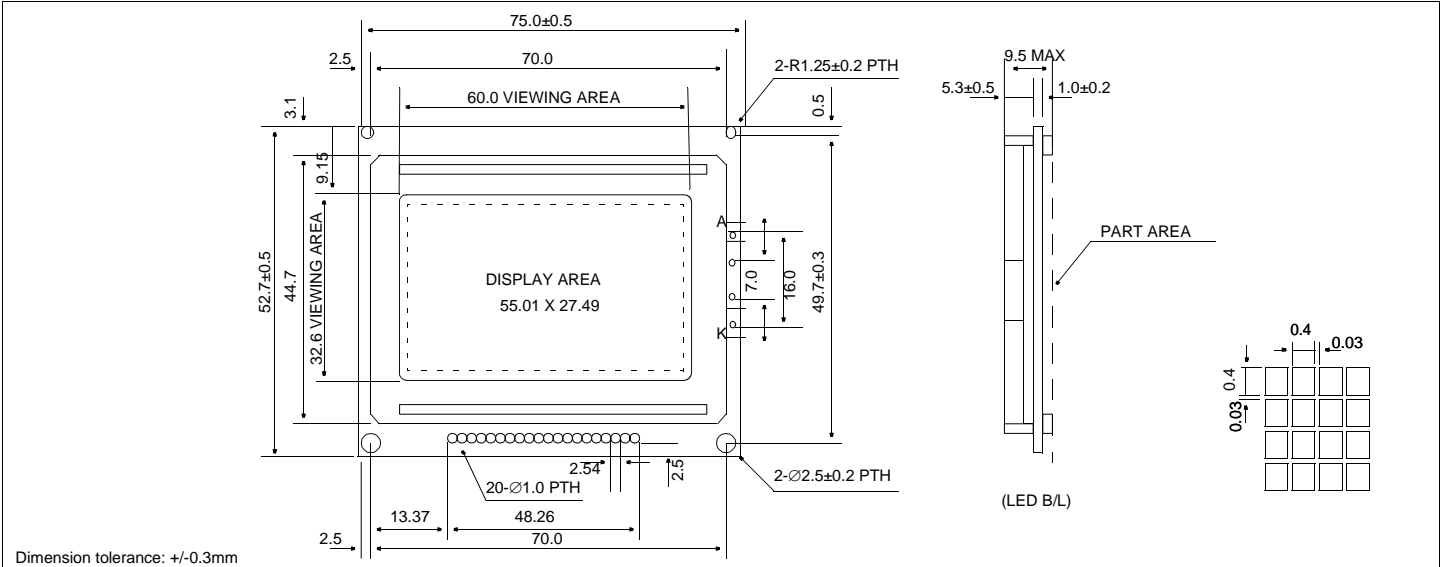

### Features

- Backlight..... LED
- Options..... Yellow STN / FSTN
- Normal/Extended Temperature
- Bottom / Top Viewing
- Built-in Controller..... Samsung KS0108
- Built-in Temperature Compensation

### Physical Data

- Module Size (LED Backlight).....75.0W x 52.7H x 9.5T mm
- Viewing Area Size.....60.0W x 32.6H mm
- Dot Pitch.....0.43W x 0.43H mm
- Dot Size.....0.40W x 0.40H mm
- Weight.....35.6g (LED)

### Power Supply

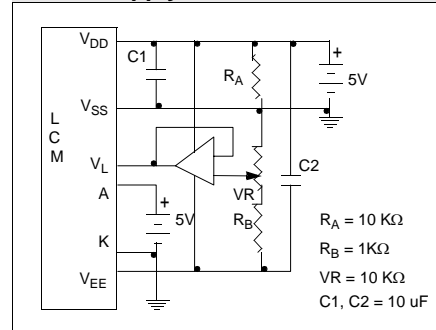

### Absolute Maximum Ratings

PARAMETER	SYMBOL	MIN	MAX	UNIT
SUPPLY VOLTAGE	$V_{DD}-V_{SS}$	- 0.3	7.0	V
SUPPLY VOLTAGE FOR LCD	$V_{DD}-V_L$	0	21.0	V
INPUT VOLTAGE	$V_{IN}$	- 0.3	$V_{DD}$	V
OPERATING TEMPERATURE	$T_{OP}$	0	50	$^{\circ}\text{C}$
STORAGE TEMPERATURE	$T_{STG}$	- 20	70	$^{\circ}\text{C}$

### Electrical Characteristics (VDD=5.0±0.25V 25°C)

PARAMETER	SYM	CONDITION	MIN	TYP	MAX	UNIT
INPUT HIGH VOLTAGE	$V_{IH}$	-	0.7 $V_{DD}$	-	$V_{DD}$	V
INPUT LOW VOLTAGE	$V_{IL}$	-	0	-	0.3 $V_{DD}$	V
POWER SUPPLY FOR LCD	$V_{DD}-V_L$	$T_A=25^{\circ}\text{C}$	8.4	8.7	9.0	V
POWER SUPPLY CURRENT	$I_{DD}$	$V_{DD}=5.0\text{V}$	-	2.0	5.0	mA
LED B/L Supply Current	$I_{LED}$	$V_L=5.0\text{V}$	-	150	200	mA
DRIVE METHOD	1/64 Duty					

### Pin Connections

PIN NO.	SYMBOL	LEVEL	FUNCTION
1	$V_{DD}$	5V	Power supply for logic
2	$V_{SS}$	0V	Ground
3	$V_L$	-	Operating voltage for LCD
4	DB0	H/L	Data bus
5	DB1	H/L	
6	DB2	H/L	
7	DB3	H/L	
8	DB4	H/L	
9	DB5	H/L	
10	DB6	H/L	
11	DB7	H/L	
12	CS1	L	Chip Select 1
13	CS2	L	Chip Select 2
14	RST	L	Reset
15	R/W	H/L	1=Read, 0= Write
16	D/I	H/L	1=Data, 0=Instruction
17	E	H/H->L	Enable
18	$V_{EE}$	OUTPUT	#
19	A	-	Anode, LED Backlight
20	K	-	Cathode, LED Backlight

# Has built-in inverter for negative power supply